



Thank You for purchasing this

Factory Service Manual on EBAY

from PCTECHINFO!



[Click Here](#) for more Factory Service

Manuals for other Computer and

Printer / Copier Manufacturers

from PCTECHINFO!

OKIDATA®

Service Manual

OL840

LED Page Printer

Adobe Acrobat printable reference
copy of the OKIDATA Service Training Manual.
09/17/97

Note: This Adobe Acrobat version of the Okidata Service Training Manual was built with the pictures rendered at 300 dpi, which is ideal for printing, but does not view on most displays well.

Service Guide OL840**0 About This Manual**

Front Cover	1
Copyright	2
Manual Revision	3

1 Product Specifications

1.1 Overview	4
1.2 Product Specifications	5
1.3 Paper Specifications	6
1.4 Physical Specifications	7
1.5 Power Requirements	8
1.6 Environmental Conditions	9
1.7 Agency Approvals	10

2 Principles of Operation

2.1 Overview	11
2.2 Printer Overview	12
....2.2.02 Main Control Unit	13
....2.2.03 Main Controller Board (RPSS)	14
....2.2.04 Program ROM Board (RPSR)	15
....2.2.05 Connection Board (LNKZ)	16
....2.2.06 Expansion RAM Board (REXM)	17
....2.2.07 Font Card	18
2.3 Printer Control Unit	19
....2.3.02 Engine Driver Board (LLAB-2)	20
....2.3.03 Power Supply Unit	21
....2.3.04 Fuser Unit	22
....2.3.05 Main Motor (Drum Motor)	23
....2.3.06 LED Array	24
....2.3.07 Resist Motor	25
....2.3.08 DC Fan	26
....2.3.09 Operation Panel	27
....2.3.10 Second Paper Tray Mechanism (Option)	28
....2.3.11 Sensor Functions	29

3 Maintenance & Disassembly

3.1 Maintenance	30
....3.1.02 Maintenance Tools	31
....3.1.03 Maintenance Precautions	32
3.2 Disassembly/Assembly Procedures	33
....Sequence of Procedures	34
....3.2.01 Main Controller Board (RPSS)	35
....3.2.02 Program ROM Board (RPSR)	36
....3.2.03 Optional Expansion RAM Board (REXM)	37
3.3 Adjustments And Service Checks	38

Table of Contents	Page
3.4 Cleaning	39
3.5 Lubrication	40
3.6 Consumables	41
4 Failure & Repair Analysis	
4.1 OL840 Troubleshooting	42
....4.1.02 LCD Display Messages (PostScript Mode)	43
A Reference Charts	
A.1 Overview	44
A.2 Charts	45
....A.2.01 Main Control Board (RPSS)	46
....A.2.02 Program ROM Board (RPSR)	47
....A.2.03 RAM Board (REXM) (Option)	48
B Illustrated Parts Listing	
OI800/OI820/OI840 Parts Compatibility List	49
....Interchangeable Parts (OL800, OL820 and OL840)	50



Service Guide OL840 Chapter 0 About This Manual

This document may not be reproduced without written permission of the Okidata® Technical Training Group. Every effort has been made to ensure the accuracy of the information contained in this training course. Okidata is not responsible for errors beyond its control.

© 1994 by Okidata All rights reserved.

First Edition, March 1992

Second Edition May, 1994

Written and produced by the Okidata Technical Training Group

Please address any comments on this publication to:

Technical Training Group

Okidata

532 Fellowship Road

Mount Laurel, NJ 08054-3499

Fax Number: (609) 235-2600, ext. 7034

Okilink Login Name: Technical Training

OKIDATA is a registered trademark of Oki Electric Industry Company, Ltd.; Marque deposee de Oki Electric Industry Company, Ltd.; Marca Registrada, Oki Electric Industry Company, Ltd.

BAR CODES PLUS, MICRO DOCS and OKIPRO 65 are trademarks of OKIDATA, Division of OKI America, Inc.

Adobe, Adobe Illustrator, and PostScript are registered trademarks of Adobe Systems Incorporated.

Apple, AppleTalk, LaserWriter, LaserWriter II, LocalTalk, and Macintosh, are registered trademarks of Apple Computer, Incorporated.

Bitstream is a registered trademark and Dutch, Fontware, and Swiss are trademarks of Bitstream, Inc. Fontware is licensed to Bitstream, Inc., in West Germany, France, and the United Kingdom by Electronic Printing Systems, Ltd.

Diablo 630 is a registered trademark of Xerox Corporation.

Helvetica, Optima, Palatino, Present and Times are registered trademarks of Linotype AG and/or its subsidiaries.

Hewlett-Packard, HP, LaserJet, and LaserJet Series II are registered trademarks of Hewlett-Packard Company.

IBM, PC, PC-DOS, and Proprinter XL are registered trademarks of International Business Machines Corporation.

Copyright 1997, Okidata, Division of OKI America, Inc. All rights reserved. See the OKIDATA Business Partner Exchange (BPX) for any updates to this material. (<http://bpx.okidata.com>)



Note: The OL800/820 Service Training course is part of the OL-Series Training Course and can not be purchased separately.

© 1994 by Okidata All rights reserved.
First Edition, March 1992
Second Edition May, 1994

Written and produced by the Okidata Technical Training Group

THE OL400/800/820/830/840 VIDEO TRAINING KIT covers the following products:

- o OL400
- o OL800
- o OL820
- o OL830
- o OL840

The following items are included in the kit:

- o OL400 Service Handbook
- o OL800/820 Service Handbook
- o OL830 Service Handbook
- o OL840 Service Handbook
- o Service Training Video
- o OL400/800/820 User's Documentation
- o OL830 User's Documentation
- o OL840 User's Documentation

Price: \$95.00 (\$124.00 Canadian)

P/N 58226902

Copyright 1997, Okidata, Division of OKI America, Inc. All rights reserved. See the OKIDATA Business Partner Exchange (BPX) for any updates to this material. (<http://bpx.okidata.com>)

1.1 OVERVIEW

1.1.01 General Information

The OL840 is an 8 page per minute page printer, with true Adobe Postscript capability. The OL840 uses a stationary LED head and dry electrophotography as its exposure and development methods.

In addition to supporting Adobe Postscript (35 Fonts), the OL840 provides two additional emulations. The HP Laserjet Series II emulation has 36 resident fonts. The Diablo 630 emulation has 18 resident fonts. Two optional font cards can be installed with the Diablo and HP emulations. Six cards are available at this time. The OL840 also accepts HP compatible downloadable fonts.

A 2MB page memory is standard on the OL840; this can be expanded to 4MB with an optional RAM printed circuit board.

A Centronics parallel interface, an RS-232C serial interface and an AppleTalk interface are standard.

Two consumables are used in the printer. The toner cartridge kit contains a toner cartridge, a fuser cleaner pad, and an LED lens cleaner. The other consumable, the image drum cartridge kit, includes an image drum cartridge and an ozone filter. Toner and drum life depend on printer use. Based on a 5% print density and 10 pages per job, a toner cartridge should last approximately 2,500 pages; a drum should last approximately 15,000 pages.

A 200 sheet letter-size paper tray is included with the printer, and a second tray can be added, providing an additional 200 pages. Legal, Envelope, Executive and A4 paper trays are also available. Paper feeding can be done automatically or manually. Pages can be printed face-down or face-up. A rear exit path is provided for items such as: card stock, envelopes, labels or overhead transparencies.

An OL800 may be upgraded to an OL840 by removing the Program Cartridge and replacing the Main Controller Board with the Postscript Controller Board.

The OL840 Printer is a member of the family of OL Series Printers which presently includes the OL400, OL800, OL820 and OL830. Okidata's own proprietary engine assures built-in quality and reliability.

1.2 PRODUCT SPECIFICATIONS

1.2.01 Print Specifications

Development method: Dry electrophotography
Exposure method: Stationary LED head

1.2.02 Print Speed

First print: 28 seconds maximum (letter size)
Continuous print: 8 sheets/minute (letter size)
Warm-up time: 40 seconds maximum [at room temperature 77oF (25oC) and rated voltage (120 VAC)]
Postscript Initialization time: 120 seconds maximum [with 4 MB memory installed and "Do Start Page" deselected]

1.2.03 Symbol Sets

HP Emulation:
Thirty-nine symbol sets are available through the OL840.

1.2.04 Available Fonts

Postscript: 35 Adobe Fonts
HP Emulation: 36 resident fonts (HP A,B,C,F,L,Y,S1 and S2 Cartridge Fonts)
Diablo 630 Emulation: 18 resident fonts

1.2.05 Paper Feed Method

Automatic feed
Manual Feed

1.2.06 Paper Delivery Method

Face down/face up

1.2.07 Print Resolution

300 x 300 dots/inch

1.2.01 Print Specifications

Development method: Dry electrophotography
Exposure method: Stationary LED head

1.2.02 Print Speed

First print: 28 seconds maximum (letter size)
Continuous print: 8 sheets/minute (letter size)
Warm-up time: 40 seconds maximum [at room temperature 77oF (25oC) and rated voltage (120 VAC)]
Postscript Initialization time: 120 seconds maximum [with 4 MB memory installed and "Do Start Page" deselected]

1.2.03 Symbol Sets

HP Emulation:
Thirty-nine symbol sets are available through the OL840.

1.2.04 Available Fonts

Postscript: 35 Adobe Fonts
HP Emulation: 36 resident fonts (HP A,B,C,F,L,Y,S1 and S2 Cartridge Fonts)
Diablo 630 Emulation: 18 resident fonts

1.2.05 Paper Feed Method

Automatic feed
Manual Feed

1.2.06 Paper Delivery Method

Face down/face up

1.2.07 Print Resolution

300 x 300 dots/inch

1.3 PAPER SPECIFICATIONS

1.3.01 Paper Types

Letter

Size: 8.5" x 11"
Feed: Automatic or Manual
Weight: Minimum 16 lbs
Maximum 24 lbs
Recommended 20 lbs

Legal

Size: 8.5" x 14"
Feed: Automatic (with optional paper tray) or Manual
Weight: Minimum 16 lbs
Maximum 24 lbs
Recommended 20 lbs

Executive

Size: 7.25" x 10.5"
Feed: Automatic (with optional paper tray) or Manual
Weight: Minimum 16 lbs
Maximum 24 lbs
Recommended 20 lbs

A4

Size: 8.27" x 11.69"
Feed: Automatic (with optional paper tray) or Manual
Weight: Minimum 16 lbs
Maximum 24 lbs
Recommended 20 lbs

Envelopes

Size: Minimum 3.5" x 7.5"
Maximum 7.2" x 10.1"
Feed: Automatic (with optional paper tray) or Manual
Weight: Minimum 16 lbs
Maximum 24 lbs
Recommended 20 lbs

Labels - Manual feed / Face up delivery only

Use labels designed specifically for laser printers.
Transparencies - Manual feed / Face up delivery only
Must be able to withstand the heat of the fusing process.

CAUTION:

Envelopes, labels, and transparencies should only be fed from the top paper tray.

Copyright 1997, Okidata, Division of OKI America, Inc. All rights reserved. See the OKIDATA Business Partner Exchange (BPX) for any updates to this material. (<http://bpx.okidata.com>)



1.4 PHYSICAL SPECIFICATIONS

1.4.01 Outside Dimensions

Width: 17.72"

Height: 9.49"

Length: 17.72"

1.4.02 Printer Weight

37 lbs.

1.4.03 LED Array

Number of LED Elements - 2560

1.5 POWER REQUIREMENTS

1.5.01 Input Power

120 VAC +5.5%, -15%
220/240 VAC +/-10%

1.5.02 Power Consumption

Approximately 800 W maximum during operation

Copyright 1997, Okidata, Division of OKI America, Inc. All rights reserved. See the OKIDATA Business Partner Exchange (BPX) for any updates to this material. (<http://bpx.okidata.com>)

1.6 ENVIRONMENTAL CONDITIONS**1.6.01 Ambient Temperature and Relative Humidity**

Operation

50° to 89° F

10° to 32° C

20 to 80% Relative Humidity

Storage

14° to 122° F

10° to 50° C

1.6.02 Printer Noise Level

During operation: 50 dB maximum

At standby: 43 dB maximum



Service Guide OL840

Chapter 1 Product Specifications

1.7 AGENCY APPROVALS

FCC Class B
UL 478 Ver.5
CSA 22.2 220

Copyright 1997, Okidata, Division of OKI America, Inc. All rights reserved. See the OKIDATA Business Partner Exchange (BPX) for any updates to this material. (<http://bpx.okidata.com>)

2.1 OVERVIEW

2.1.01 Outline of Printer Operation

The primary control boards of the printer are the Engine Driver Board (LLAB-2) and the Main Controller Board (RPSS). The Engine Driver Board controls the printer mechanism and drives the LED head. The Main Controller Board receives data from the host device, analyzes commands, and processes the data for printing. To help you understand the structure of the printer system, refer to the Printer Block Diagram.

The RPSS PCB is connected to the host system through a Centronics parallel interface, RS-232C interface or an AppleTalk interface. Interface selection is accomplished through menu settings. Once an interface is selected, the remaining interface connectors output BUSY (Emulation Mode only). The Main Controller Board receives print data and command strings from the host system, and generates bit image data. When one page of print data is ready, the Main Controller Board turns on the PRINT-N signal which is one of the video interface signals. Upon receipt of the PRINT-N signal, the Engine Driver Board turns ON the main motor, resist motor, and fuser in preparation for printing. The Engine Driver Board then sends the FSYNC-N and LSYNC-N signals to the Main Controller Board.

Once the Main Controller Board receives the FSYNC-N and LSYNC-N signals, the WDATA-N signal (image data signal) is sent to the Engine Driver Board in synchronization with the WCLK-N signal. The Engine Driver Board turns ON the appropriate LEDs in conformance with the WDATA-N signal.

In addition to the above, the Engine Driver Board controls the paper feed, paper transport, and xerographic processing actions necessary for printing.

The Operation Panel is connected to the Main Controller Board via the LLCC PCB, the Engine Driver Board and the LNKZ PCB. The Operation Panel is controlled by the Main Controller Board. The optional Second Paper Tray (LLFC PCB) is controlled by the Engine Driver Board.

The Main Controller Board contains 2 MByte of dynamic RAM. The Expansion Memory Board (REXM) provides an additional 2 Mbyte of dynamic RAM.

Two font cards slots are available. Each font card contains ROM which provides additional fonts. The two connectors for the font cards are provided on the CMBZ PCB. The font card data is sent to the Main Controller Board through the LNKZ PCB.

2.2 PRINTER OVERVIEW

2.2.01 General Information

This section describes the operation of the OL840 Printer in the following order:

- Main Control Function
 - Printer Control Function
 - Mechanical Operation
 - Sensors and Switches
-

Copyright 1997, Okidata, Division of OKI America, Inc. All rights reserved. See the OKIDATA Business Partner Exchange (BPX) for any updates to this material. (<http://bpx.okidata.com>)

2.2.02 Main Control Unit

The control unit controls reception of the data from the host through the interface, processes command analysis, bit image development, and raster buffer read. It also controls signal flow with the Engine Driver Board and the Operator Panel.

Reception Control

The control unit has three interface ports: centronics parallel, RS-232C serial, and Appletalk/RS-422 serial ports. Through the MENU, one of the I/F ports can be selected at a time. The other ports output BUSY in emulation mode, but not in PostScript mode. The Appletalk port is the default port.

Command Analysis Processing

The OL840 has PostScript and the following emulation modes which are selected through the printer MENU:

- LaserJet Series II: Hewlett Packard
- Diablo 630: Xerox

In the Postscript mode, each typeface style is stored as a series of outlines, one for each character, comprised of lines and Bezier curves. The shape of each character in a typeface style is actually determined by a mathematical formula. When the document is to be printed, the host sends information to the printer in the form of the Postscript page description language. The printer then reads the file it receives, sizes and orients each character outline as required, and prints the page.

In the HP and Diablo modes, the OL840 prints fonts as bit-mapped outlines. The outline of each character is determined by placing dots in a grid. A complete set of these grids, one for each character in the font, is stored in ROM. Since no special calculations are used in the HP mode, each typeface, style, weight, orientation and size is stored separately.

Down Line Loaded (DLL) fonts and macro registration are stored in the DLL and macro areas of memory (RAM) Emulation and Postscript interpretation is performed under program control by the CPU.

Font Processing

In the emulation mode, the bit image in the font ROM is loaded by the CPU into the raster buffer (RAM). The raster buffer has a band buffer structure, new data is written to the raster buffer once the buffer has been read and becomes empty.

In Postscript mode, the outline data stored in the programmed ROM is loaded into the RAM area called the font cache, the required font pattern is then transferred to the raster buffer. The buffer has a full-page buffer structure. One page of data is written at a time. After a page is written, another raster buffer read operation starts.

Raster Buffer Read Operation

The bit image written to the raster buffer by the CPU is converted to serial dot data to be read in

response to the VIDEO SYNCH signal.

The first in-first out (FIFO) buffer is between the raster buffer and the serial dot data of the video interface (WDATA).

The CPU can transfer data from the raster buffer to the FIFO automatically when the CPU reads the "OR-ING" memory area of the raster buffer. The CPU reads a line of data from the raster buffer before the LSYNC signal is received from the Engine Driver Board.

Once LSYNC is received, reading starts. Then, in response to WCLK, parallel to serial conversion and data transfer takes place.

The amount of data that is read from the FIFO is sensed by the 64NC22VIA counter. The CPU writes another line of data to the FIFO, immediately after a line of data is read from the FIFO.

Engine I/F Processing

The engine I/F is divided into the engine control interface and the command interface. The engine control interface signal is allocated to a signal line through bits of the register (TTL). The CPU can obtain the engine status by sensing each bit, or run the engine by manipulating each bit.

The command I/F is a bidirectional serial signal. The register (TTL) is used for serial-parallel or parallel-serial conversion.

Operation Panel Control

The operation panel I/F is a bidirectional serial Interface. Each signal line is allocated to the 65NC22VIA port. The CPU then sends the shift clock and executes serial or serial-parallel conversion.

Copyright 1997, Okidata, Division of OKI America, Inc. All rights reserved. See the OKIDATA Business Partner Exchange (BPX) for any updates to this material. (<http://bpx.okidata.com>)

2.2.03 Main Controller Board (RPSS)

The Main Controller Board (RPSS) can be accessed from the rear of the printer. The RPSS board consists of the CPU, RAM, VIA, FIFO, SCC, and one gate array. The CPU is a MC68000 with a clock frequency of 12.5MHz.

Sixteen 1Mbit (1 bit x 1Mbit) dynamic RAM chips are mounted as resident RAM (total 2Mbytes). The VIA (Versatile Interface Adapter) ICO6G (65NC22) controls the Operation Panel interface, Printer Unit interface, read/write operations of FIFO (IC14G) and the EEPROM IC05H (X24C16). The FIFO (First in-First out Buffer) connects the CPU to the video interface. The FIFO has a capacity of over 2 lines (2 rasters). The data written to the FIFO by the CPU is sequentially read according to the VIDEO I/F synchronous signal.

The Serial Communications Controller (SCC) controls the RS-232C interface, RS-422 interface, and the AppleTalk interface. The RS-422 and AppleTalk interfaces use the same connector and are usable only in the PostScript mode.

Copyright 1997, Okidata, Division of OKI America, Inc. All rights reserved. See the OKIDATA Business Partner Exchange (BPX) for any updates to this material. (<http://bpx.okidata.com>)

2.2.04 Program ROM Board (RPSR)

The Program ROM (RPSR) Board is connected to the Main Controller Board. The RPSR board consists of:

- Ten 1 Mbit EPROM chips (eight are for PostScript - two are for Emulation Mode)
 - Two 4 Mbit MASK ROM chips which store the bit-map fonts used in HP Laserjet and Diablo emulations
 - Three TTL IC chips, which function as an address decoder.
-

Copyright 1997, Okidata, Division of OKI America, Inc. All rights reserved. See the OKIDATA Business Partner Exchange (BPX) for any updates to this material. (<http://bpx.okidata.com>)



Service Guide OL840

Chapter 2 Principles of Operation

2.2.05 Connection Board (LNKZ)

The LNKZ connection board contains a buffer used to connect the optional font cards to the Main Controller Board.

Copyright 1997, Okidata, Division of OKI America, Inc. All rights reserved. See the OKIDATA Business Partner Exchange (BPX) for any updates to this material. (<http://bpx.okidata.com>)

2.2.06 Expansion RAM Board (REXM)

Sixteen 1Mbit (1bit x 1Mbit) dynamic RAM (total 2M bytes) are mounted to the Expansion RAM Board. The RAM capacity is detected during the power-on sequence. The RAM capacity is printed during **MENU PRINT** in the Emulation Mode or **START PAGE** in Postscript mode.

Copyright 1997, Okidata, Division of OKI America, Inc. All rights reserved. See the OKIDATA Business Partner Exchange (BPX) for any updates to this material. (<http://bpx.okidata.com>)

2.2.07 Font Card

Up to two font cards for additional fonts can be installed. If the printer is in the off-line state (the READY lamp is off), the cards can be inserted and removed without removing power. When the font card is inserted and removed in the on-line state (the READY lamp is on), the message, **CARD REMOVED ONLINE**, will be displayed on the Operation Panel.

Copyright 1997, Okidata, Division of OKI America, Inc. All rights reserved. See the OKIDATA Business Partner Exchange (BPX) for any updates to this material. (<http://bpx.okidata.com>)

2.3 PRINTER CONTROL UNIT

2.3.01 General Information

The principal hardware components of the printer control unit are listed below.

- Engine Board
 - Power Supply Unit
 - Fuser Unit
 - Main Motor
 - LED Head
 - Sensors and Switches
 - Resist Motor
 - Fan
 - Operation Panel
 - Second Paper Tray Mechanism (option)
-

Copyright 1997, Okidata, Division of OKI America, Inc. All rights reserved. See the OKIDATA Business Partner Exchange (BPX) for any updates to this material. (<http://bpx.okidata.com>)

2.3.02 Engine Driver Board (LLAB-2)

The Engine Driver Board contains an 80C51 Microprocessor (8-bit), an EPROM which stores the Engine Control Program and an EEPROM.

The Engine Driver Board turns the LED Array diodes ON, to place an electrostatic image on the photosensitive drum. The Engine Driver Board also controls the paper feed, paper transport, and electrophotographic processing actions so that the electrostatic image can be printed by fusing toner on the paper.

The 1-Kbit Electrically Erasable PROM (EEPROM) is loaded with the data listed below.

- Total number of sheets printed after installation
- Modified page count
- Total number of sheets printed with the current drum
- Total number of sheets printed with the current fuser
- Setting of time required from the completion of printing to Quiet Mode
- Feed time needed to feed the paper to a printable position
- Vertical Registration (Top margin)
- LED head drive time

Notes:

The EEPROM preserves the data while the supply voltage is off.

The counters stored in the EEPROM can be accessed by using SW1 on the Engine Board to place the printer in the Maintenance MODE. (See Section 3)

The count of the total number of sheets printed after installation cannot be reset.

The count of the total number of sheets printed with the drum currently in use should be taken as a rough measure of the useful life of the drum: It is reset to zero when the drum is replaced by holding down the RESET button and applying power to the printer.

2.3.03 Power Supply Unit

The power supply unit generates the following voltages from the AC input voltage:

High Voltage Drive

The high-voltage circuit provides the charge voltage (about -6 Kvdc), transfer voltage (about +5 Kvdc), grid voltage (about -600vdc), and developer bias voltages (about -550vdc and -400vdc). Of these voltages, the charge voltage and the transfer voltage are generated by a high-voltage power supply. The grid connects to ground via a varistor on the medium-voltage generation circuit. This keeps the grid at about -680vdc during charging.

Low Voltage Circuit

This circuitry produces the voltages listed below.

- +5 vdc: Printer Logic
- +/- 12 vdc: Interface Signal Levels
- +38 vdc: Resist/Main Motor Drive, Fan Drive

Note:

+5 vdc and +38 vdc are also supplied to the LLFC on the 2nd Paper Tray Mechanism

2.3.04 Fuser Unit

The Fuser Unit is controlled by a thermistor, a comparator, an LSI, and the CPU to keep the heat roller surface temperature within a predetermined range (about 150 degrees Celsius). A thermal fuse within the Fuser Unit prevents abnormal temperature rises in case the thermistor fails.

Note:

The CPU checks for an open circuit in the thermistor at power -on, setting a fuser alarm if this error is detected.

The CPU also sets a fuser alarm if the proper temperature is not attained within a specified period of time after power-on.

Upon detecting a fuser alarm, the CPU will halt (after printing the current page.)

2.3.05 Main Motor (Drum Motor)

The Main Motor is controlled by the motor control LSI, IC5 (M54646). The motor used is a four-phase motor, driven by the DM-PHL 1, 2, 3 and 4 signals generated by the LSI.

Copyright 1997, Okidata, Division of OKI America, Inc. All rights reserved. See the OKIDATA Business Partner Exchange (BPX) for any updates to this material. (<http://bpx.okidata.com>)



2.3.06 LED Array

Data for the 2,560 LEDs in the LED Array is placed in the shift register by the HD CLK signal. The data is loaded in the latch circuit by the HD LD signal.

Copyright 1997, Okidata, Division of OKI America, Inc. All rights reserved. See the OKIDATA Business Partner Exchange (BPX) for any updates to this material. (<http://bpx.okidata.com>)

2.3.07 Resist Motor

The Resist Motor is driven clockwise for hopping, then counterclockwise for Paper Feeding by the motor drive IC (LB1731).

Copyright 1997, Okidata, Division of OKI America, Inc. All rights reserved. See the OKIDATA Business Partner Exchange (BPX) for any updates to this material. (<http://bpx.okidata.com>)

2.3.08 DC Fan

The fan is controlled by the FAN ON-P signal from the LSI (MSM73H019). In order for the printer to operate, the signal FAN SENSE-N must be active.

Note:

The fuser and the fan are not enabled when the cover is open. If the fan fails to run, the fuser will turn off and FAN ALARM is set. Printing is disabled.

In accordance with the TIME TO QUIET setting of the level 2 Menu, the Fuser will maintain the proper fusing temperature for 1 or 8 minutes after the last page has been printed. If printing is not requested within the selected time frame, the fuser will turn OFF and the fan speed will be reduced 50%. Selecting DISABLE allows the FUSER to maintain the proper fusing temperature continuously.

Copyright 1997, Okidata, Division of OKI America, Inc. All rights reserved. See the OKIDATA Business Partner Exchange (BPX) for any updates to this material. (<http://bpx.okidata.com>)

2.3.09 Operation Panel

The following components make up the operation panel:

- 4-bit MPU (LC6543C)
- LCD control driver (MSM6222B or HD44780)
- LCD display (16 characters per line)
- Operation panel sheet
- LEDs (for online mode indication)

Operation Buttons

The Operation Panel is connected to the Main Controller Board via the Engine Connection Board, the Engine Driver Board and the Program Cartridge Connection Board. The Operation Panel is controlled by the Main Controller Board.

The LCD control driver (MSM6222B or HD44780) converts 4-bit character codes received from the MPU into 8-bit character codes and retrieves the character pattern data (font) from the internal character generator for display on the LCD.

Operation Panel Interface

The operation panel is controlled by the operation panel interface located on the Main Controller Board. Control is via the Engine Driver Board.

2.3.10 Second Paper Tray Mechanism (Option)

The Second Paper Tray Mechanism is controlled by the Second Tray Driver Board (LLFC). This board is attached to the left side of the second paper tray mechanism. The resist motor and paper tray detection sensors for the second paper tray are mounted on this board.

Copyright 1997, Okidata, Division of OKI America, Inc. All rights reserved. See the OKIDATA Business Partner Exchange (BPX) for any updates to this material. (<http://bpx.okidata.com>)

2.3.11 Sensor Functions

The following alarms are detected by sensors and switches.

During Power ON

The inlet and outlet sensors are checked for their on and off states at power on time.

- Inlet sensor on: Inlet jam error (paper supply jam)
- Outlet sensor on: Outlet jam error (paper eject jam)

The thermistor sensor detects if the fuser temperature reaches the desired temperature within the specified time. If the desired temperature is not reached, the fuser is turned **OFF**.

The fan sensor circuitry checks for the rotation of the fan. If fan motion is not detected, the fuser is turned **OFF**, and power is removed from the fan.

When a paper cassette with no paper loaded has been detected, the Paper-End Sensor sends the **PAPER END** signal to the Control Unit.

When the power supply is turned **ON**, the number of printed pages of the fusing unit and drum cartridge is checked. If the Fuser or Drum life has been exceeded, this information is transmitted to the Control Unit.

During Hopping

Whenever the inlet sensor fails to detect paper within a predetermined time after a feed command has been issued to the paper supply system, the failure is counted. The hopping operation is then attempted up to three times. If the hopping operation still fails, an **INLET JAM ERROR** is displayed on the Operation Panel.

During Feeding

If the leading part of the paper does not reach the outlet sensor within a predetermined time after the start of feeding by the resist motor, a **FEED JAM ERROR** will be displayed on the Operation Panel.

3.1 MAINTENANCE

3.1.01 General Information

This section lists the parts replacement, adjustment, cleaning, and lubrication procedures.

Disassembly should not be performed unless absolutely necessary. **NEVER** perform disassembly on a malfunctioning unit

Follow the procedures listed in Adjustments and Service Settings. Adjustments may be required when either consumables

Cleaning procedures must be performed correctly if high print quality is to be achieved.

3.1.02 Maintenance Tools

The following tools are required to service the unit.

- #2 Phillips Screwdriver (with magnetic tip)
 - Straight-slot Screwdriver
 - Needle Nose Pliers (4 Inch)
 - Digital Multimeter
 - Shop Vacuum (with filter for toner)
 - Cloth (soft and lint-free)
 - All-purpose Cleaner
 - Grease (Dow Corning BR2 or equivalent)
-

3.1.02 Maintenance Tools

The following tools are required to service the unit.

- #2 Phillips Screwdriver (with magnetic tip)
 - Straight-slot Screwdriver
 - Needle Nose Pliers (4 Inch)
 - Digital Multimeter
 - Shop Vacuum (with filter for toner)
 - Cloth (soft and lint-free)
 - All-purpose Cleaner
 - Grease (Dow Corning BR2 or equivalent)
-

Copyright 1997, Okidata, Division of OKI America, Inc. All rights reserved. See the OKIDATA Business Partner Exchange (BPX) for any updates to this material. (<http://bpx.okidata.com>)

3.1.03 Maintenance Precautions

- Do **NOT** disassemble the unit if it is operating normally.
 - Before starting disassembly and assembly, always power **OFF** the unit and detach the power cord.
 - Detach the interface cable, if installed.
 - Do not remove parts unnecessarily. Try to keep disassembly to a minimum.
 - Use the recommended maintenance tools.
 - When disassembling, follow the listed sequence. Failure to follow the correct sequence may result in damaged parts.
 - Screws, collars and other small parts are easily lost. Temporarily attach these parts to their original positions.
 - When handling circuit boards use extreme care. Integrated circuits (microprocessors, ROM, and RAM) can be destroyed by static electricity.
 - Do not place printed circuit boards directly on conductive surfaces.
 - Follow the recommended procedures when replacing assemblies and units.
 - Clear the drum counter when a new drum cartridge is installed.
 1. Power **OFF** the unit.
 2. Press and hold **RESET** while powering **ON** the unit.
 3. The drum counter will reset.
 - Clear the fuser counter when a new fusing unit is installed. Refer to Section 3.3, [Adjustments in this Service Handbook](#) ().
-

3.2 DISASSEMBLY/ASSEMBLY PROCEDURES

General Information

This section contains the printer disassembly procedures. Only the removal procedures are explained. Reverse the procedure for the installation.

This Service Handbook lists the disassembly procedures for major components of the unit. Okidata does **NOT** recommend disassembling a unit which is operating normally. If you decide to perform disassembly during this training, Okidata recommends that you perform **only** the disassembly procedures for RSPL items. All other procedures are provided to assist you in identifying parts. It is not likely that you will perform these procedures while servicing the product. Read all notes, cautions, and warnings. They contain important information regarding assembly/disassembly.

Copyright 1997, Okidata, Division of OKI America, Inc. All rights reserved. See the OKIDATA Business Partner Exchange (BPX) for any updates to this material. (<http://bpx.okidata.com>)



Service Guide OL840

Chapter 3 Maintenance & Disassembly

Sequence of Procedures

Note:

The disassembly procedures for the OL840 are identical to the OL800/820.

All hardware assemblies, except the Main Controller Board, Program ROM Board, and Memory Expansion Board are identical.

The OL840 does NOT use a Program Cartridge.

The only procedures listed in this manual are for the OL840 Main Controller Board, Program ROM Board, and Memory Expansion Board.

Refer to the OL800/820 Service Handbook for the remaining procedures ()

The printer will be disassembled in the order listed below.

1. Upper Cover
 2. Engine Unit
 3. LED Head
 4. Transfer Charger Assembly
 5. Paper Supply Unit
 6. Resist Motor
 7. Tray Detection Circuit Board (LLCC)
 8. Resist Roller Assembly
 9. Engine Controller Circuit Board (LLAB-2)
 10. Main Motor Assembly
 11. Idle Gears A and B, and Reduction Gear
 12. DC Fan Assembly
 13. Power Supply Unit
 14. Upper Unit
 15. Fusing Unit
 16. Backup Roller
 17. Idle Gear C
 18. Main Controller Board (RPSS)
 19. Program ROM Board (RPSR)
 20. Connection PCB (LLIC)
 21. Connection Board (LNKZ)
 22. Font Card Motherboard (CMBZ)
 23. Optional RAM PCB (REXM)
-

3.2.01 Main Controller Board (RPSS)

1. Power **OFF** the printer.
2. Remove the AC connector.
3. Remove the interface cable.
4. Pull the rear panel (1) backward and remove.
5. Loosen the four screws (2) on the inner panel (3).
6. Open the lock clips (4), and pull the main controller board (5) out.
7. Remove the inner panel.

Note:

The screws (2) are captive; they cannot be completely removed.
The Program ROM Board is not shown in this drawing.

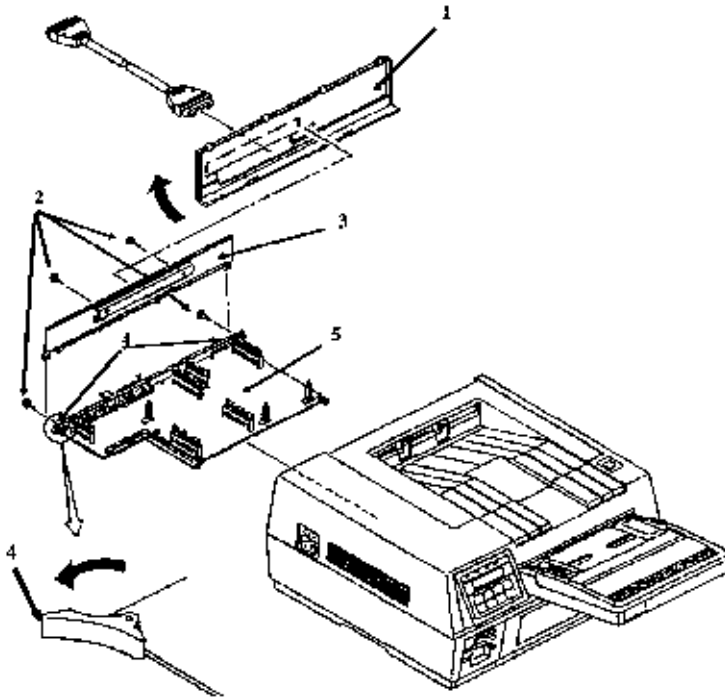

3.2.02 Program ROM Board (RPSR)

1. Remove the main controller board (RPSS). (See 3.2.01)
2. Using a needle nose pliers, detach the nylon latches (1).
3. Lift the program ROM board (2) from the main controller board being careful not to lose the circuit board retainer clip (3).

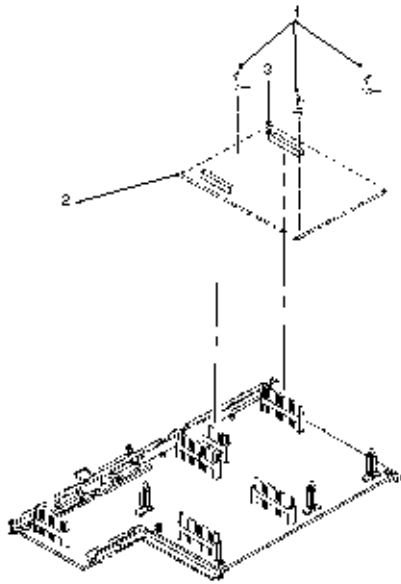

3.2.03 Optional Expansion RAM Board (REXM)

1. Remove the main controller board (RPSS). (See 3.2.01)
2. Pull up and remove the optional Expansion RAM PCB (1) from the connectors MEM (2).

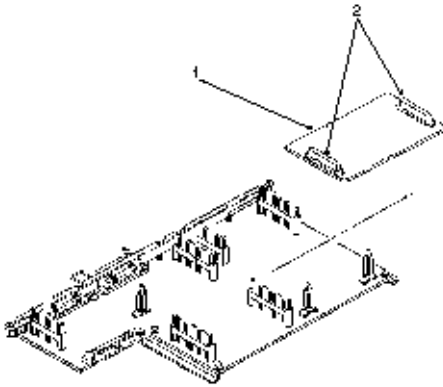

3.3 ADJUSTMENTS AND SERVICE CHECKS

3.3.01 General Information

The first four adjustments (Actual Page Count, Modified Page Count, Vertical Print Start Position and LED Head Drive Time) are performed by changing addresses on the EEPROM located on the Engine Controller Printer circuit board.

Please refer to Section Three of the OL800/820 Service Handbook for these procedures .

Copyright 1997, Okidata, Division of OKI America, Inc. All rights reserved. See the OKIDATA Business Partner Exchange (BPX) for any updates to this material. (<http://bpx.okidata.com>)



Service Guide OL840

Chapter 3 Maintenance & Disassembly

3.4 CLEANING

3.4.01 General Information

Remove any dropped toner and dust. Clean inside and around the printer with a vacuum cleaner (equipped with a toner filter) when necessary.

Refer to Section 3.4 of the OL800/820 Service Handbook for information on cleaning the printer ().

Copyright 1997, Okidata, Division of OKI America, Inc. All rights reserved. See the OKIDATA Business Partner Exchange (BPX) for any updates to this material. (<http://bpx.okidata.com>)

3.5 LUBRICATION

3.5.01 General Information

Refer to Section 3.5 of the OL830 Service Handbook for information on lubricating the printer ().

Copyright 1997, Okidata, Division of OKI America, Inc. All rights reserved. See the OKIDATA Business Partner Exchange (BPX) for any updates to this material. (<http://bpx.okidata.com>)

3.6 CONSUMABLES

The OL840 uses the same consumables as the OL800 and OL820.

3.6.01 Image Drum Counter Reset

When the image drum cartridge is replaced, the image drum counter must be reset.

1. Press and hold **RECOVER/RESET** while powering on the printer.
2. This resets the counter.

3.6.02 Ozone Filter

The ozone filter is replaced when the image drum cartridge is replaced.

1. Power off the printer.
 2. Place a screwdriver in the slot under the lower portion of the fan cover and lift the screwdriver slightly to remove the fan cover.
 3. Replace the filter.
 4. Replace the cover.
-

4.1 OL840 TROUBLESHOOTING

4.1.01 General Information

Section Four of the OL800/820 Service Handbook should be used to troubleshoot the OL840.

Listed below are the differences between troubleshooting the OL800/820 printers and the OL840 printers.

- When told to replace the CTLZ Board, replace the RPSS Board.
Both boards are Main Controller Boards.
 - When told to replace the Program Cartridge, replace the Program ROM Board.
There is no Program Cartridge in the OL840.
The printers firmware is located on the Program ROM Board.
This board is attached to the Main Controller Board.
 - When told to replace the Memory Expansion Chip Set, replace the Memory Expansion Board (REXM).
 - When the Engine Control Board (LLAB-2), is replaced, remember that the OL840 EEPROM is **NOT** identical to the OL800/820 EEPROM.
-

4.1.02 LCD Display Messages (PostScript Mode)

The following messages may be displayed when the printer is in the PostScript mode.

Refer to Section Four of the OL800/820 Service Handbook for LCD Messages displayed in the Emulation Mode (🖨️).

LCD MESSAGE	DEFINITION	CORRECTIVE ACTION
ON-LINE .PS IDLE	The printer is in the online mode.	Normal Indication
OFF-LINE .PS	The printer is in the off-line mode. The printer receives data but does not process any data.	Normal Indication
ON-LINE .PS PROCESSING	The printer is processing the received data	Normal Indication
ON-LINE .PS WAITING	Waiting for receive data.	Normal Indication
ON-LINE .PS PRINTING	The printer is printing received data.	Normal Indication
ON-LINE .PS PRINTER BUSY	The ON-LINE key is pressed during processing waiting or printing.	Recovers automatically. Otherwise press the RECOVER key to return to IDLE.
ON-LINE .PS FLUSHING JOB	After PRINTER BUSY appeared the RECOVER key was pressed and all data in the receive buffer was invalidated.	Normal Indication
DOING START PAGE	The start page setting was ON when the power was turned on. Printing starts from the start page in about one minute.	Normal Indication

ON-LINE .PS CHANGE DRUM	The drum is aging .	Replace the drum Change the software to the emulation mode hold down the recover key and turn on the power. Check that DRUM CTR RESET appears on the LCD.
ON-LINE. PS FUSER LIFE	End of thermal fuser life.	Replace the thermal fuser and reset the fuser counter.
ON-LINE .PS TONER LOW	The printer is low on toner.	Replace the toner cartridge.
WARMING UP	The printer is warming up.	Normal Indication
ERROR CARD	There is an error in the data on the font card (checksum error).	Try reinstalling the Font Card. Replace the Font Card.
INITIALIZING	Firmware is initializing	Normal Indication. Will be displayed when switching between software modes (Postscript and Emulation).

A.1 OVERVIEW

A.1.01 General Information

This section describes the characteristics of the printed circuit boards used in the printer. The following areas are covered.

- Firmware
- Fuses
- Jumpers
- Switches
- Sensors
- Test Points

Where an item is not applicable, the word **NONE** will be listed.

Copyright 1997, Okidata, Division of OKI America, Inc. All rights reserved. See the OKIDATA Business Partner Exchange (BPX) for any updates to this material. (<http://bpx.okidata.com>)

A.2 CHARTS**Index to Charts****Description Acronym Section**

Main Control Board (without ROM)	RPSS	A.2.01
Program ROM Board	RPSR	A.2.02
RAM Board	REXM	A.2.03

Copyright 1997, Okidata, Division of OKI America, Inc. All rights reserved. See the OKIDATA Business Partner Exchange (BPX) for any updates to this material. (<http://bpx.okidata.com>)



Service Guide OL840

Chapter A Reference Charts

A.2.01 Main Control Board (RPSS)

Firmware

NONE

Fuses

NONE

Jumpers

T1: +5vdc at Pin 18 of Centronics Parallel Interface
1-2: +5vdc not present
2-3: +5vdc present

T2: +5vdc at Pin 18 of RS232-C Serial Interface
1-2: +5vdc not present
2-3: +5vdc present

Sensors

NONE

Switches

NONE

Test Points

NONE

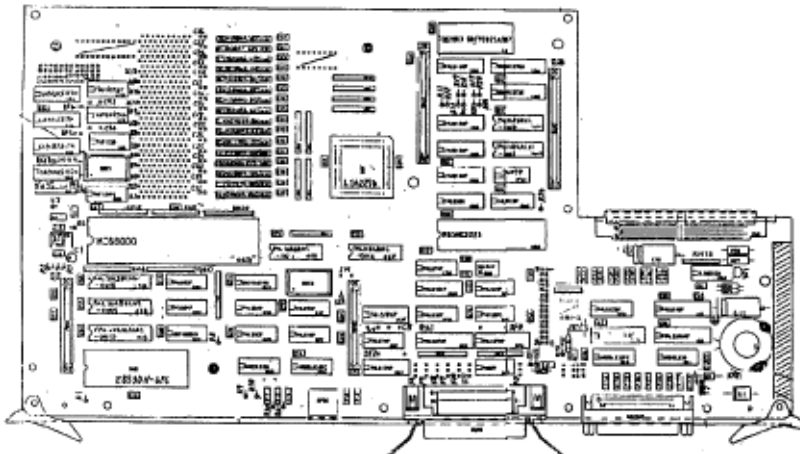

A.2.02 Program ROM Board (RPSR)

Firmware

- O1A (4M bit) (Masked) Bit-mapped Fonts
- O1B (4M bit) (Masked) Bit-mapped Fonts
- O2A through O9A (8 PROMS) - Postscript Interpreter
- O2B / O3B - Program for Emulation Mode

Fuses

NONE

Jumpers

NONE

Sensors

NONE

Switches

NONE

Test Points

NONE

Notes:

When using XON/XOFF Protocol, the OL840 will lockup when receiving serial data after the buffer fills and it attempts to send the first DC3.

In order to correct this problem on field units, FCO 7761 should be installed. The emulation PROMS (O2B, O3B) on the program ROM board (RPSR) are replaced with Rev. 1.41.

Field Units Covered by the FCO

- Serial Numbers 010A0015157 and below (120 volt)
- Serial Numbers 010A0000144 and below (220 volt)

Kit Part Number: 58221301

Order this kit through Okidata Logistics.

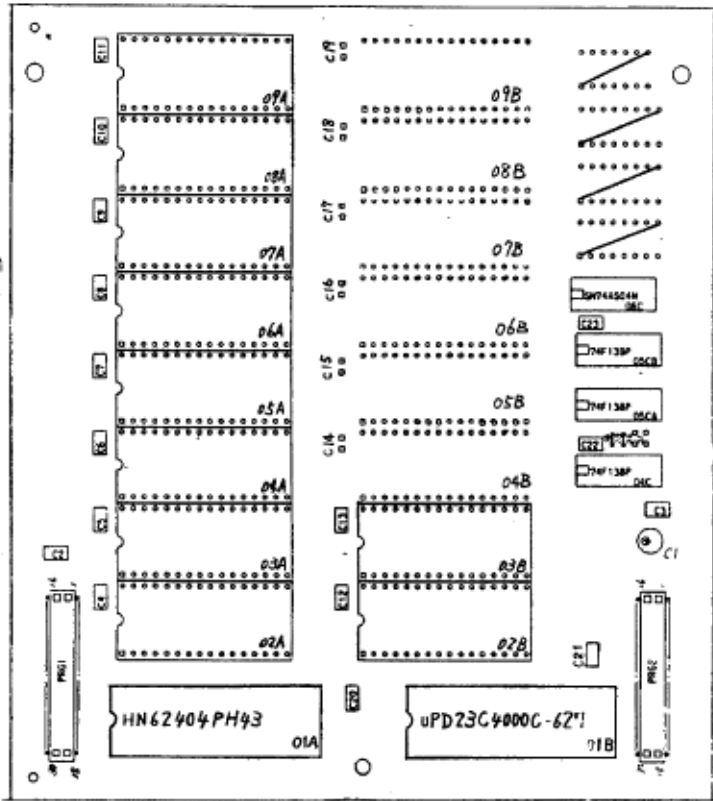

Copyright 1997, Okidata, Division of OKI America, Inc. All rights reserved. See the OKIDATA Business Partner Exchange (BPX) for any updates to this material. (<http://bpx.okidata.com>)



Service Guide OL840

Chapter A Reference Charts

A.2.03 RAM Board (REXM) (Option)

Firmware
NONE

Fuses
NONE

Jumpers
NONE

Sensors
NONE

Switches
NONE

Testpoints
NONE

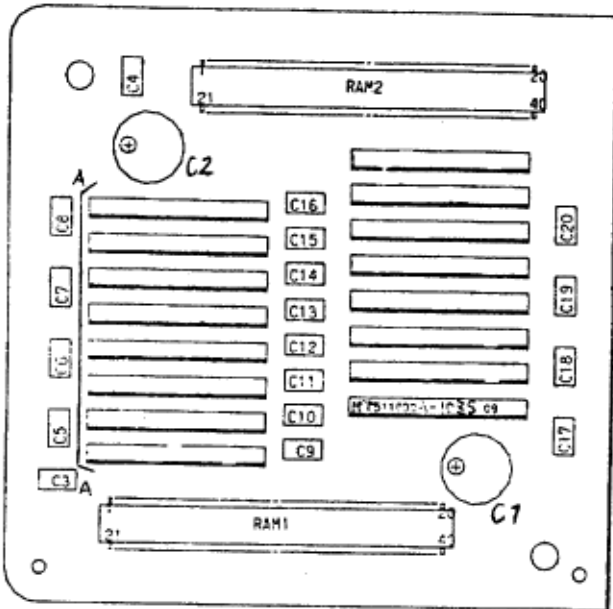

B.1 COMPATIBILITY CHARTS

Parts which are unique to the OL800 and OL820, +, +

Item	Description	Okidata Part Number
61	PCB: CTLZ (Main Controller)	55046101
62	PCB: PRGZ (w/o ROM)	55046501

Parts which are unique to the OL820, +, +

Item	Description	Okidata Part Number
63	PCB: OkiXpress Scalable Font Card (w/ROM)	21025001

Options which are interchangeable between the OL800 and OL820, +, +

Item	Description	Okidata Part Number
64	PCB: MEMZ	55046601
65	PCB: CMIZ (Multi-port)	55050001
66	PCB: RMIZ (Multi-port)	55050101

Parts Unique to the OL840

Item	Description	Okidata Part Number
67	PCB: RPSS (Main Controller Board)	55051001

68	EEPROM: For use on Engine Control Board	55921901
69	PCB: RPSR (PROM Board) w/o ROM	55051101

Options Unique to the OL840

Item	Description	Okidata Part Number
70	PCB: REXM (2MB RAM) Option	55051601

Copyright 1997, Okidata, Division of OKI America, Inc. All rights reserved. See the OKIDATA Business Partner Exchange (BPX) for any updates to this material. (<http://bpx.okidata.com>)



Service Guide OL840

Chapter B Illustrated Parts Listing

Interchangeable Parts (OL800, OL820 and OL840)

Parts which are interchangeable between the OL800,, OL820 and OL840, +, +

Item	Description	Okidata Part Number
1	Assembly: Exit Roller	50066501
2	Assembly: Face-Up Stacker	50066601
3	Cover: Upper (Program Cartridge)	50070201
4	Cover: Lower (Program Cartridge)	50070301
5	Assembly: Resist Roller	50079101
6	Assembly: Back-Up Roller	50079201
7	Assembly: Transfer Charger	50081601
8	Roller: Hopping (Assembly)	50081701
9	Panel: Operation (Assembly)	50213502
10	Unit: Lower	50213602
11	Cover: Upper (Assembly)	50213902
12	Panel: Inner	50214402
13	Unit: Paper Delivery	50214502
14	Spring: Bias (LED Head)	50914101
15	Spring: Clamp (LED)	50914301
16	Spring: Fusing Unit	50914601

17	Spring: Backup Roller	50914801
18	Spring: Cassette	50917001
19	Spring: Separator	50917101
20	Spring: Image Drum Tray	50917205
21	Gear: Idle "A"	51218401
22	Gear: Idle "B"	51218501
23	Gear: Idle (Base)	51218601
24	Gear: Speed Reduction	51218701
25	Base: Lower	53059401
26	Panel: Front (R)	53059501
27	Panel: Blind	53059601
28	Panel: Front (L)-B	53059701
29	Panel: Rear	53059801
30	Post	53329501
31	Separator	53500501
32	Fuser Pad	53500901
33	Contact: Ground	53505201
34	Foot: Rubber	53505301
35	Cable	53505430
36	Cable	53505431
37	Panel: Inner	53534201

38	PCB: LLAB-2 (Engine Controller) w/o ROM	55044402
39	PCB: LLCC (Engine Connection)	55044601
40	Unit: Fusing (120V)	55044901
41	PCB: LLID	55046001
42	PCB: CMBZ	55046201
43	PCB: LLIC	55046301
44	PCB: LNKZ	55046401
45	PCB: LLBB High Voltage	55047301
46	Microswitch Assembly - Cover Open	55050701
47	Filter: Ozone	55503501
48	Unit: LED Head	55619501
49	IC: EEPROM (LLAB) 84	55921901
50	Power Supply (120V)	56407702
51	Motor: Pulse (Resist)	56507401
52	Motor: Pulse (Main)	56507701
53	Assembly: DC Fan	56508501
54	Cord: AC	56609701
55	Connector: AKJ-40A	56725201
56	Unit: Upper (240V)	50213702
57	Roller: Hopping (2nd Tray)	53534301
58	Unit: Fusing (240V)	55044902

59	PCB: LLFC (2nd Tray)	55051401
60	Power Supply (240V)	56408102

Copyright 1997, Okidata, Division of OKI America, Inc. All rights reserved. See the OKIDATA Business Partner Exchange (BPX) for any updates to this material. (<http://bpx.okidata.com>)